

# G5 (Att)

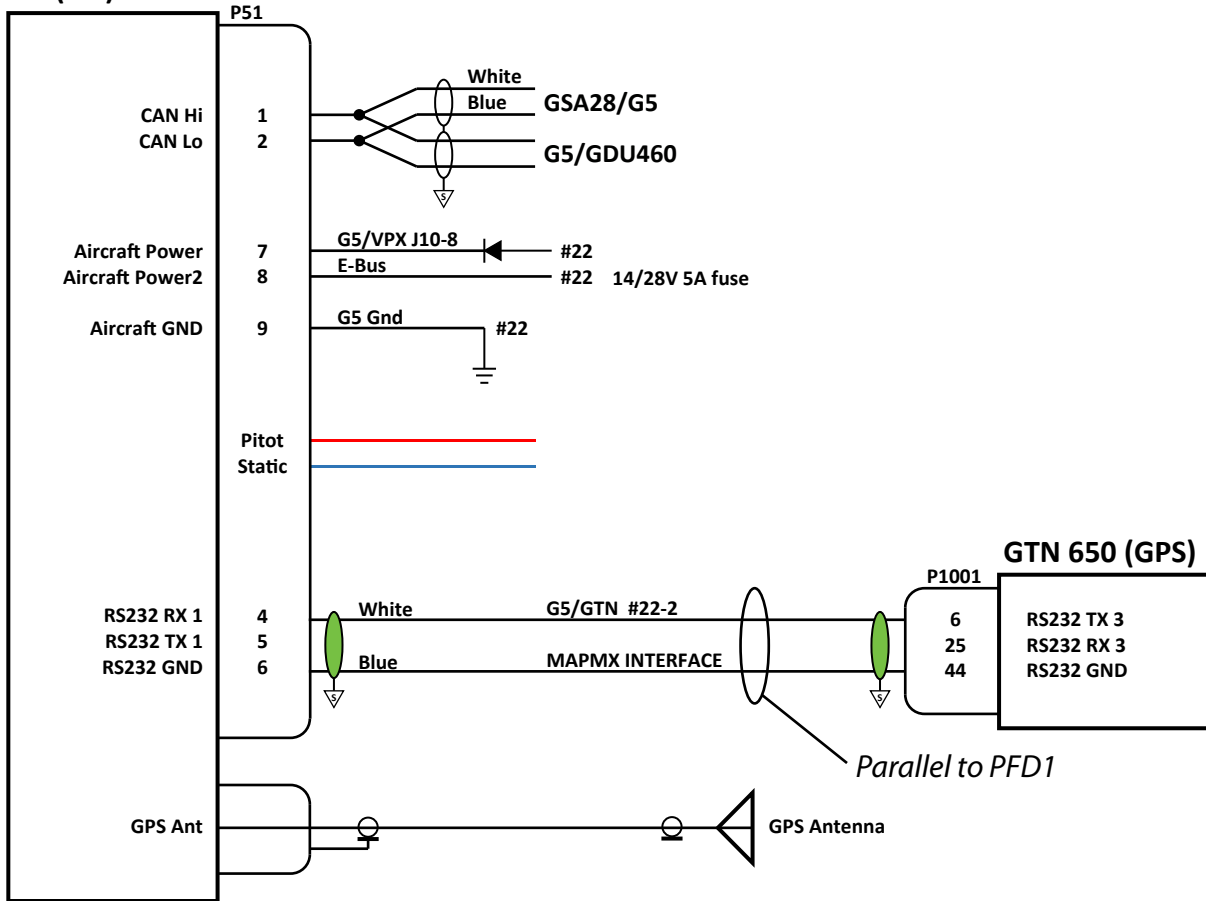

## CAN BUS Order

- 1 GSA 28
- 2 G5
- 3 GDU 460
- 4 GDU 460
- 5 GMA 245
- 6 GMC 507
- 7 GDU 460
- 8 GTX45R
- 9 GAD 13
- 10 GAD 29
- 11 GSU 25
- 12 GEA 24
- 13 GTR 20
- 14 GSA 28
- 15 GSA 28
- 16 GMU 11

# GDU 460 (PFD1)

PAGE 27-2

PAGE 27-36

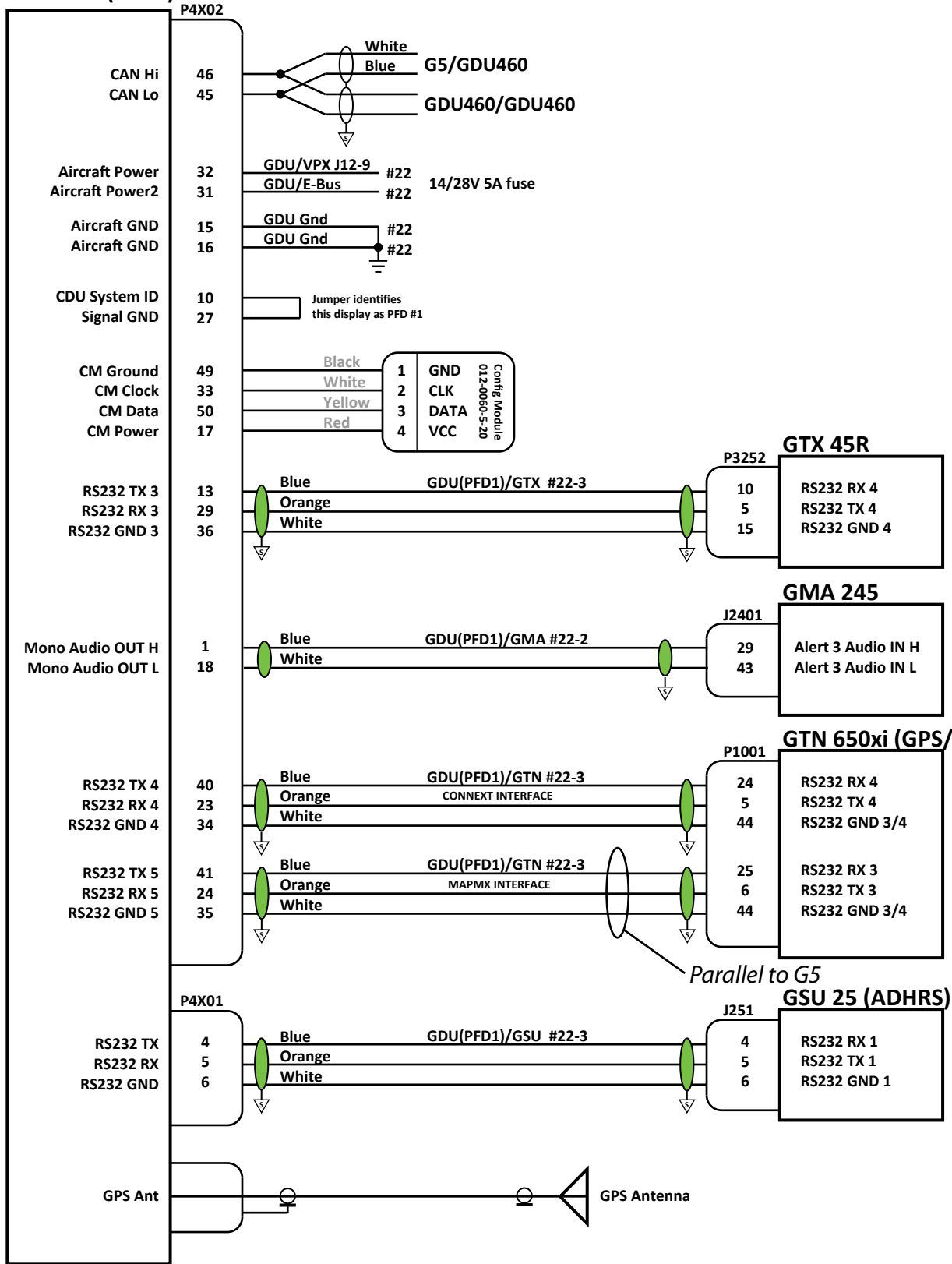

# GDU 460 (MFD)

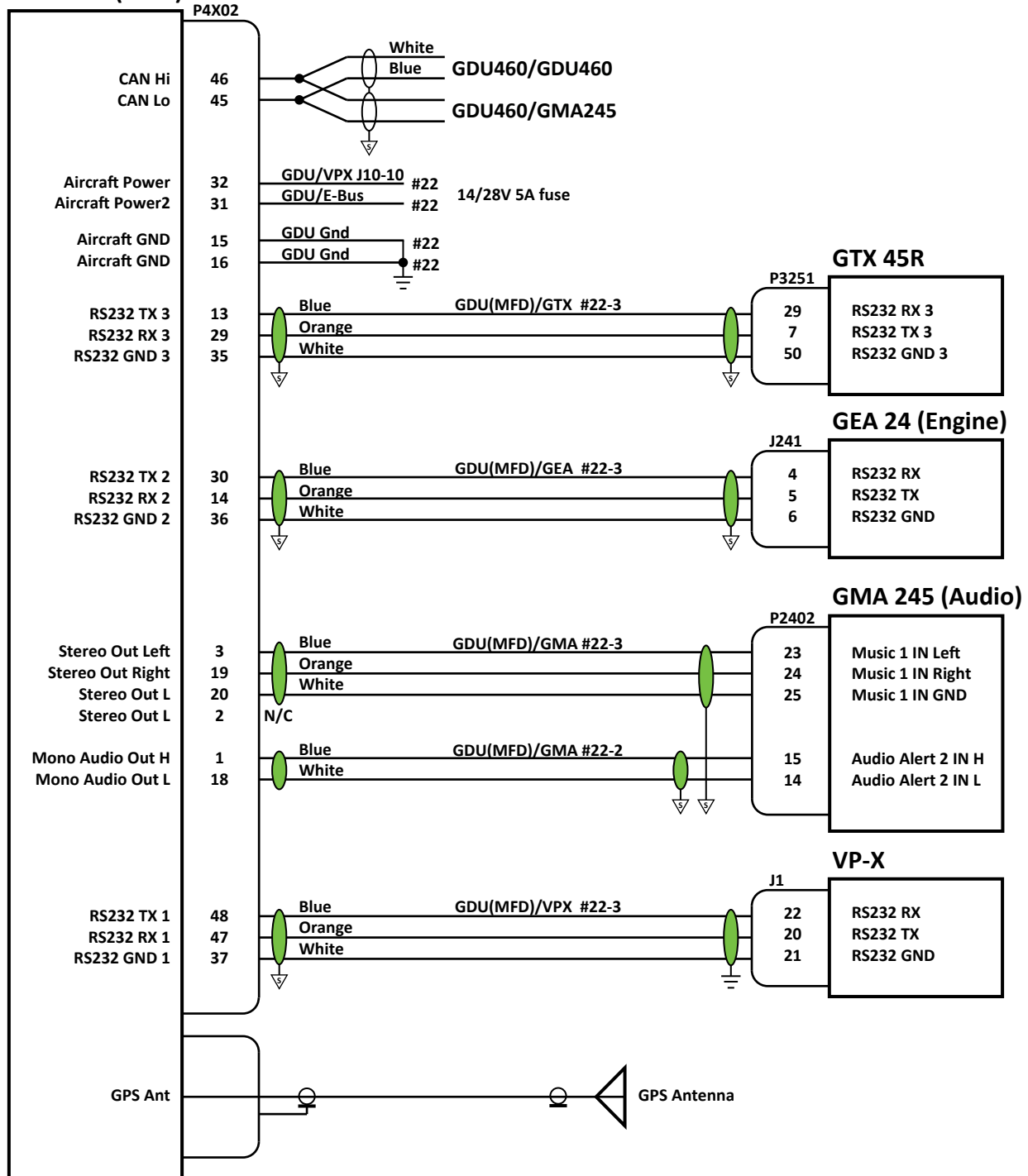

### GDU 460 (PFD2)

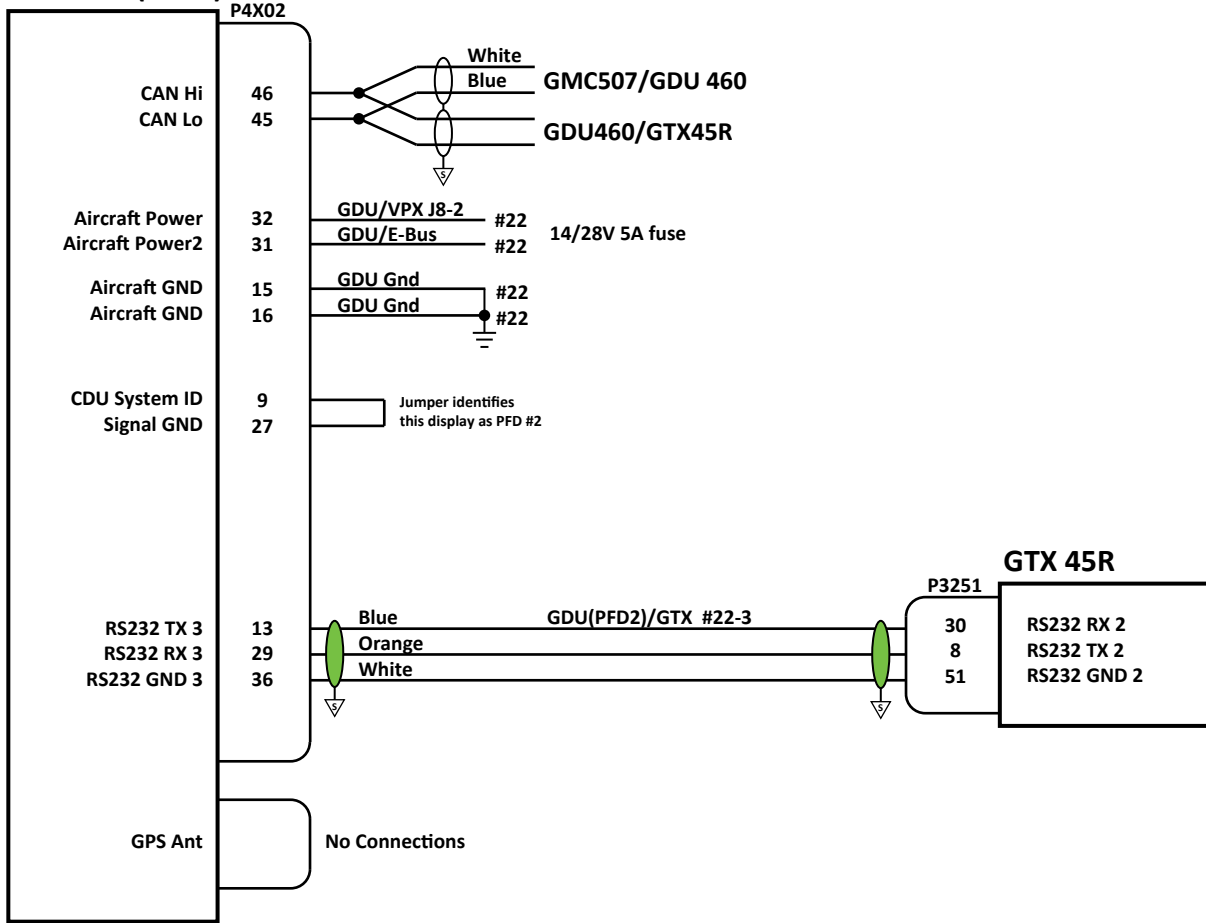

### GTX 45R

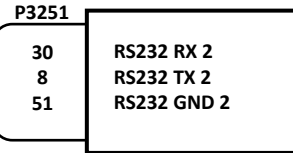

# GTN 650xi (GPS/NAV/COM)

PAGE 27-36

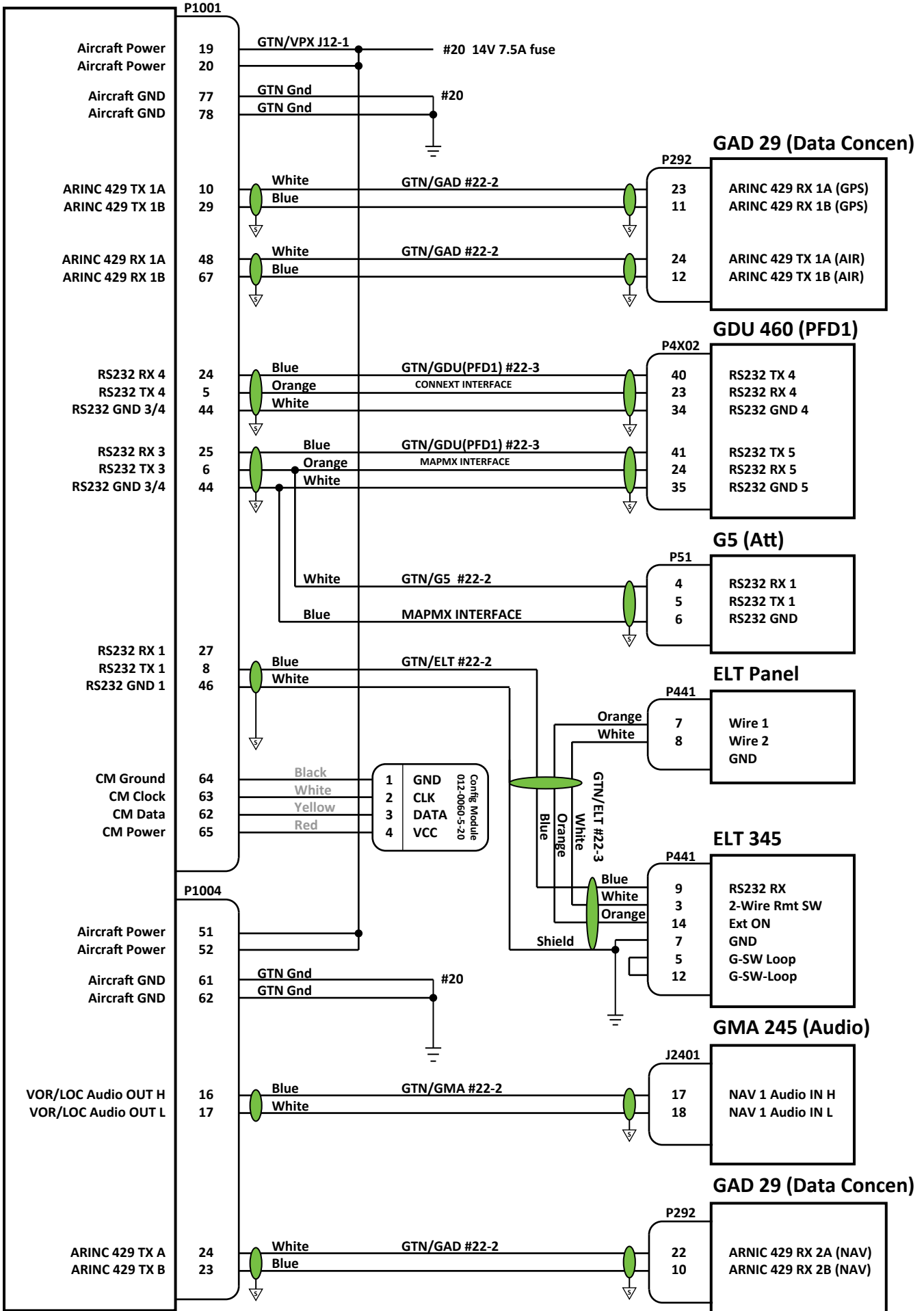

**GTN 650xi (GPS/NAV/COM)**

**GTX 45R (XPDR)**

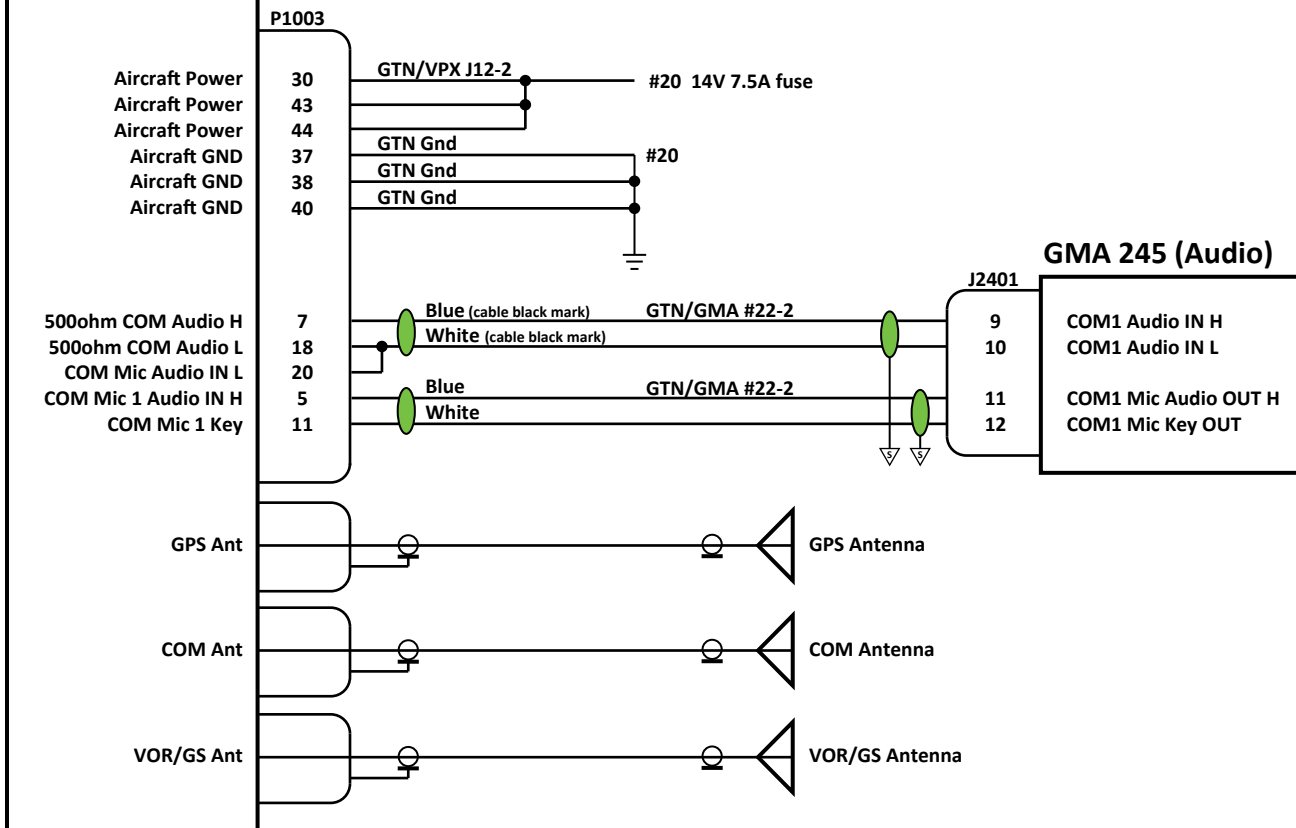
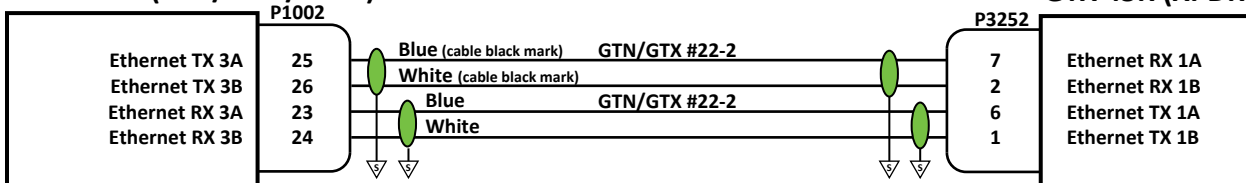

**GAD 29 (Data Concn)**

**GTN 650xi (GPS/NAV/COM)**

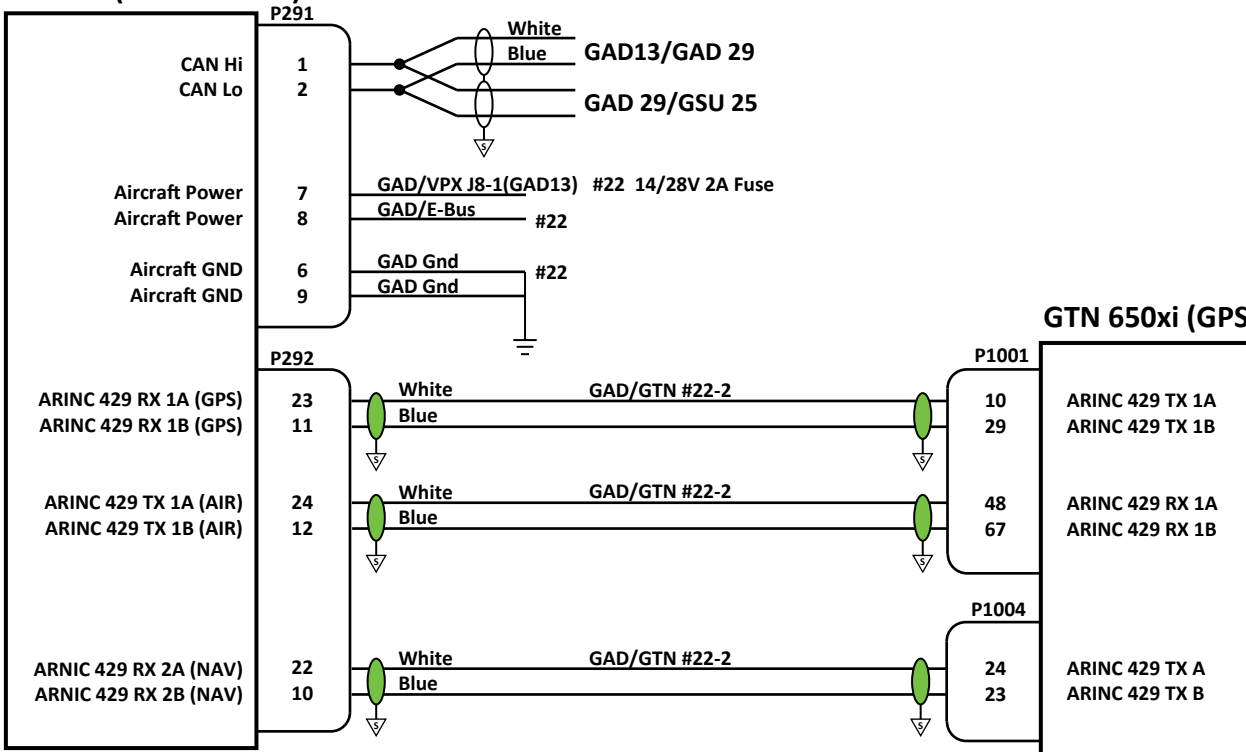

# GMA 245 (Audio)

J2401

PAGE D4

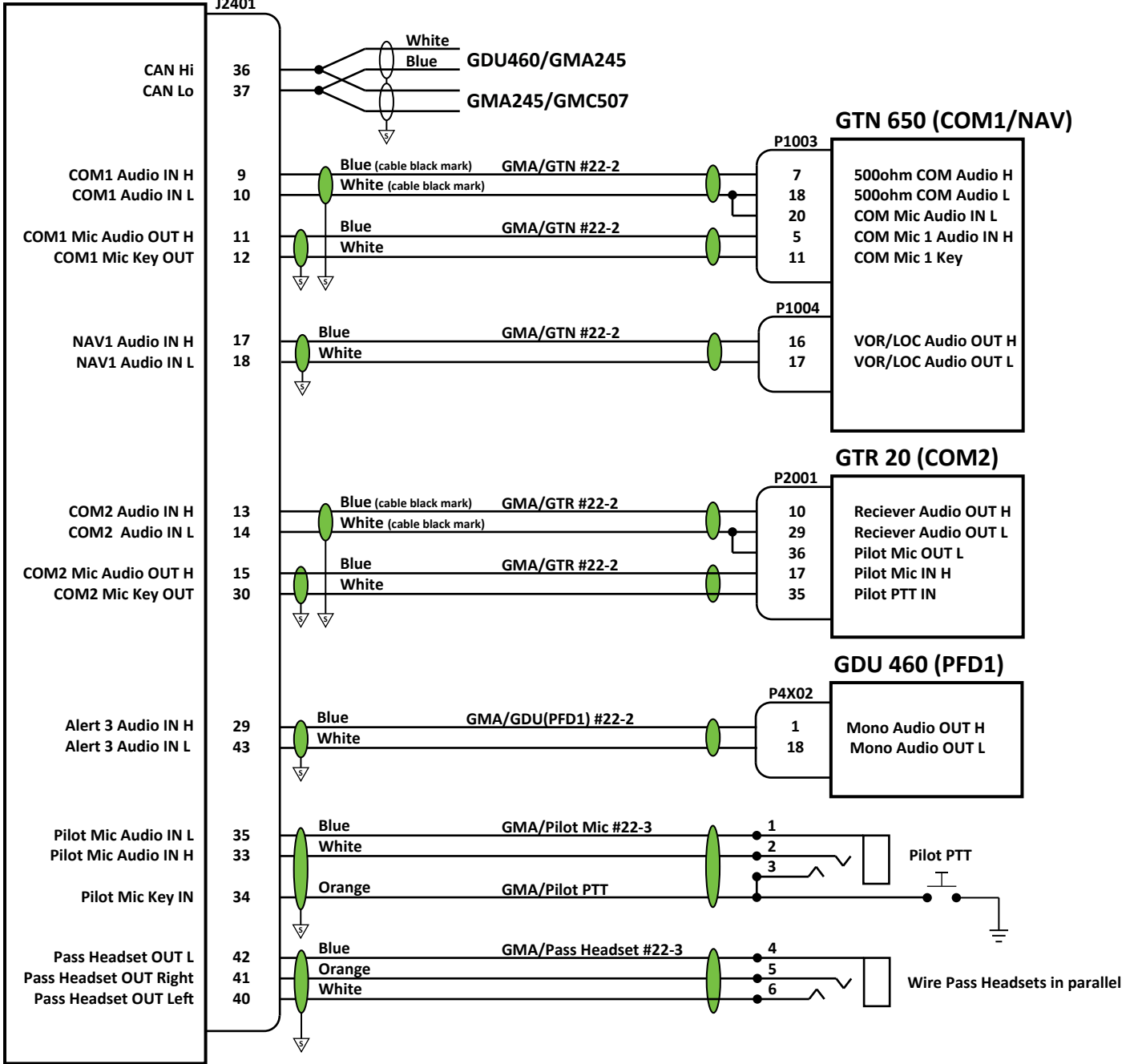

# GMA 245 (Audio)

J2402

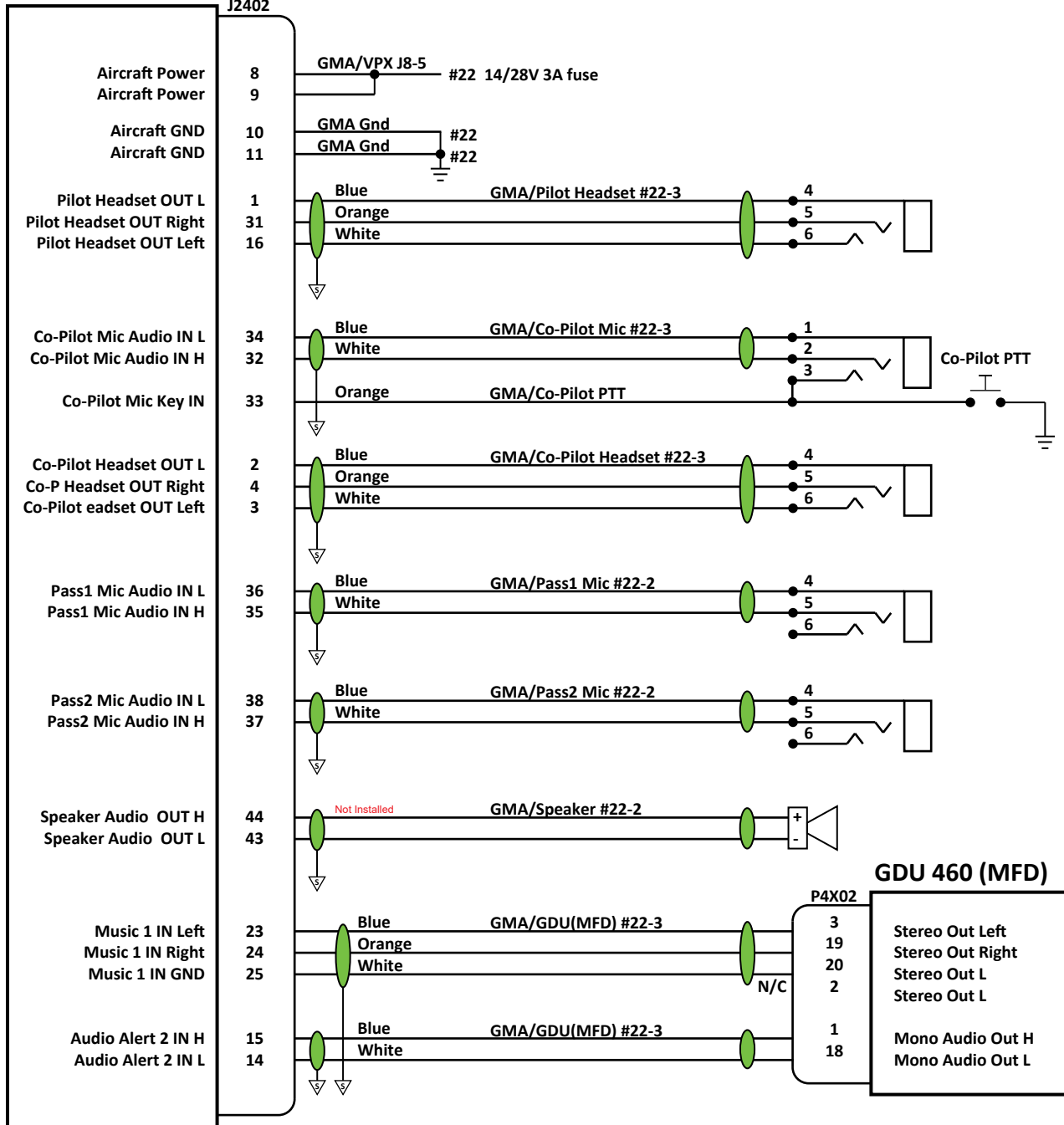



# GTX 45R (XPDR)

PAGE C-2

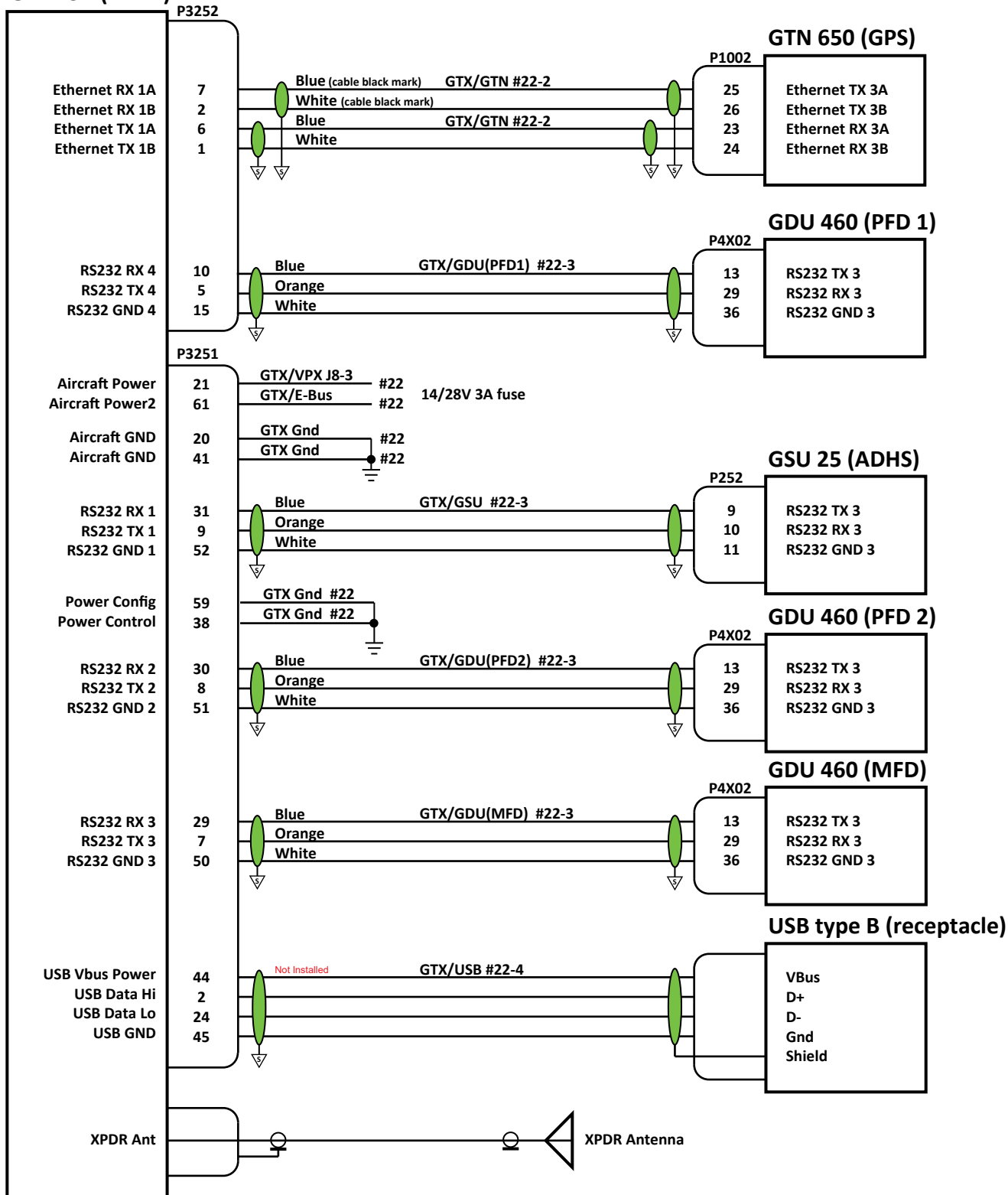

### GTR 20 (COM 2)

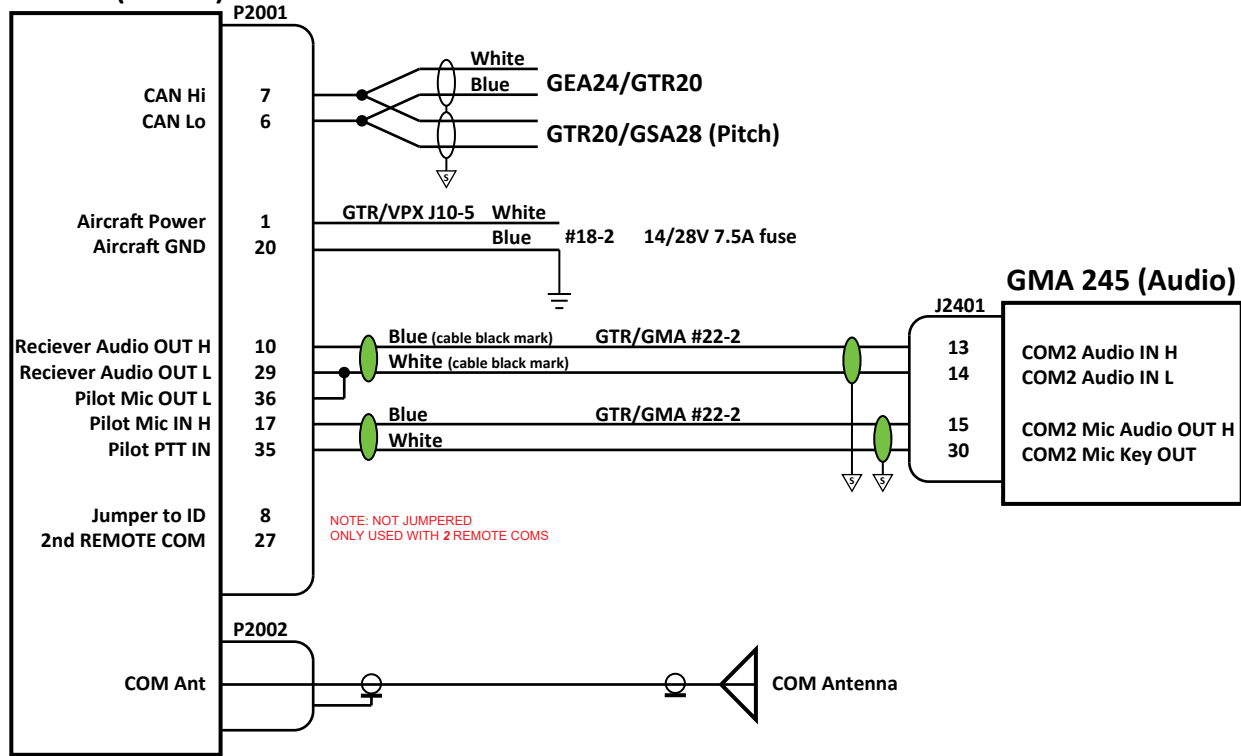

### GMU 11 (Magnetometer)

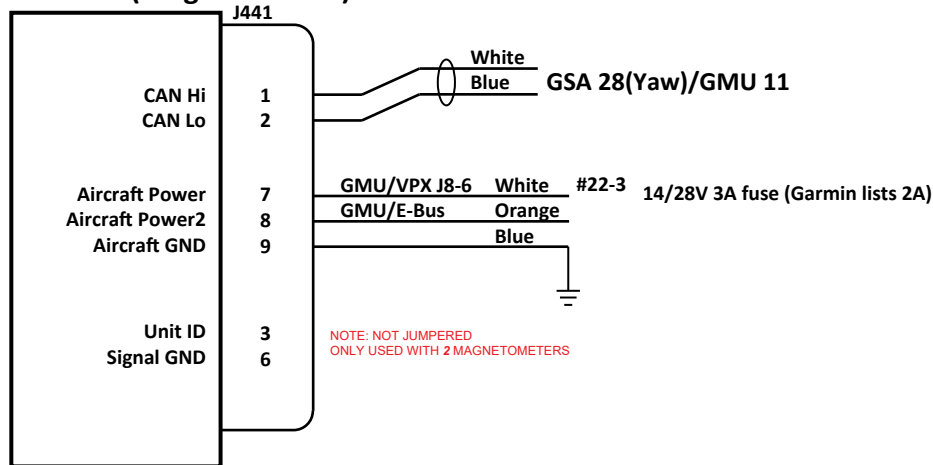

### GMC 507 (A/P)

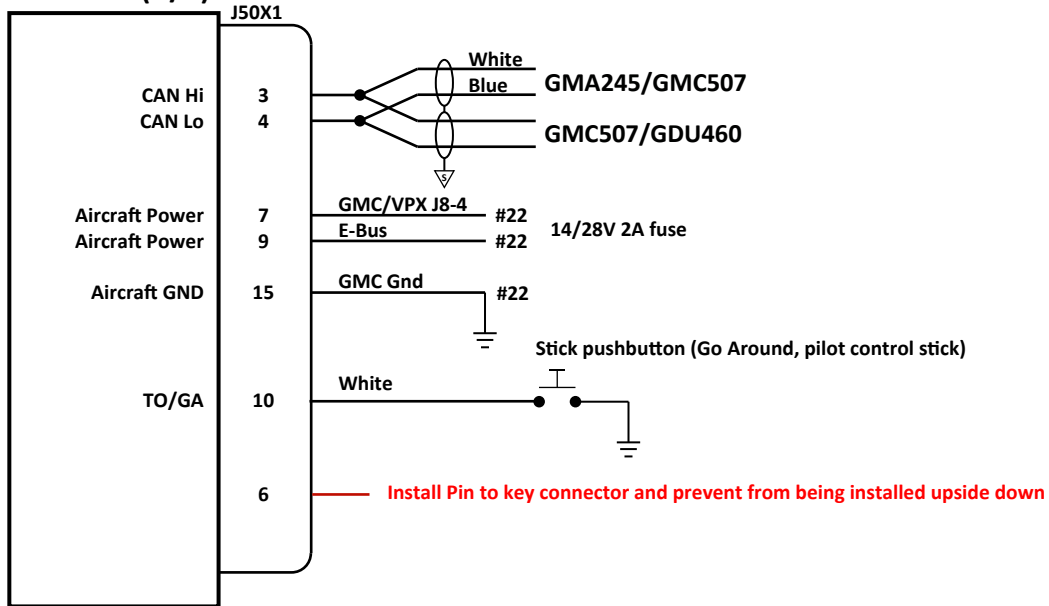

### GSA 28 (Roll Servo)

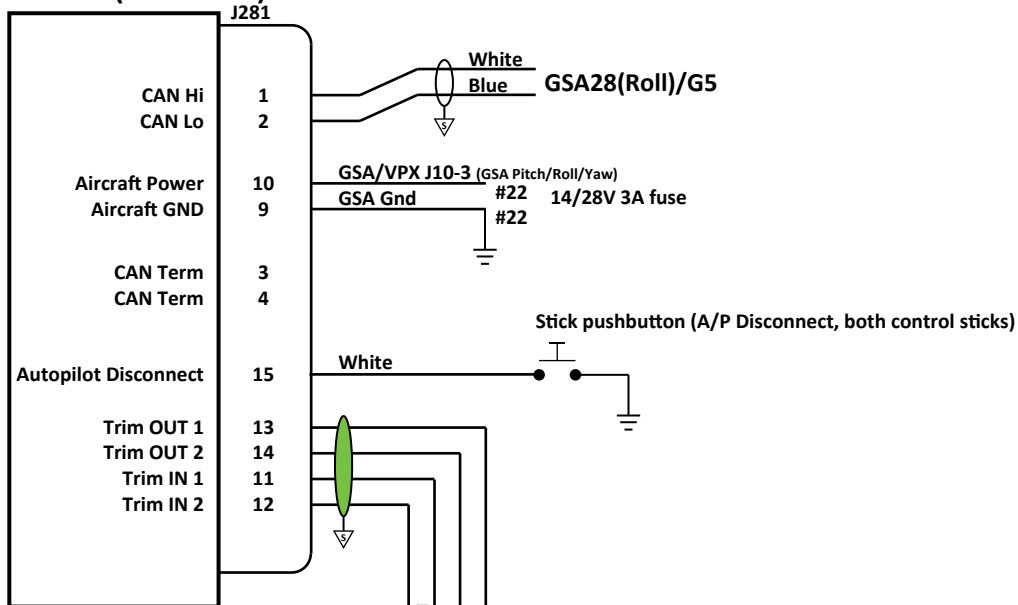

### VP-X

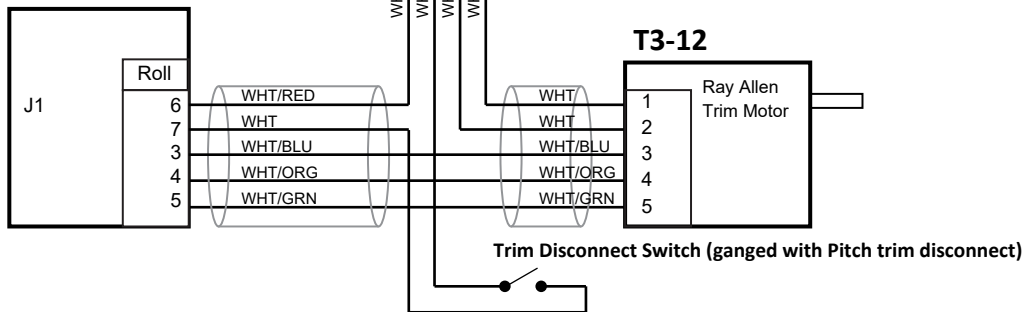

### GSA 28 (Pitch Servo)

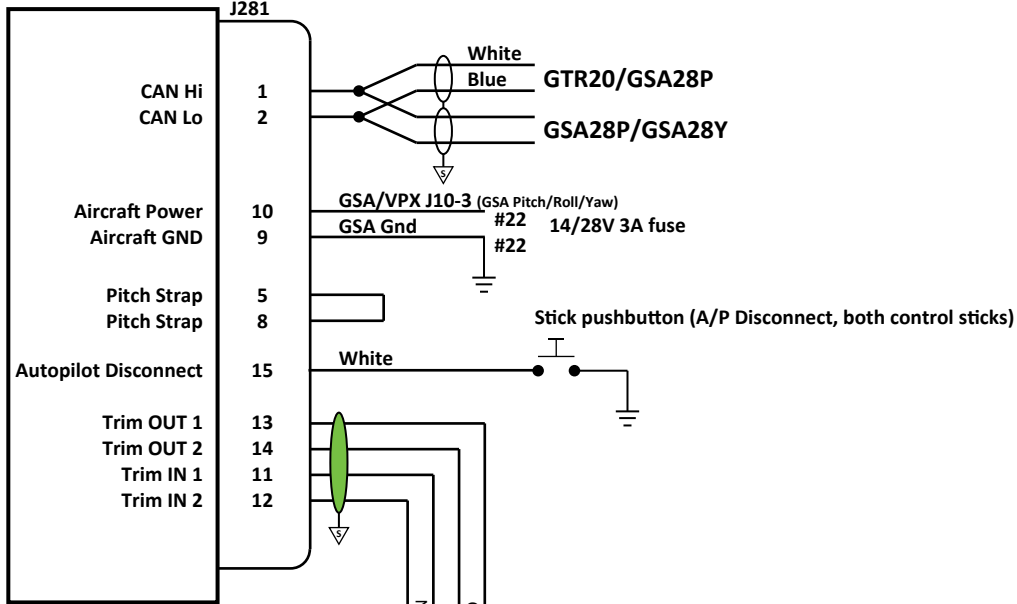

### VP-X

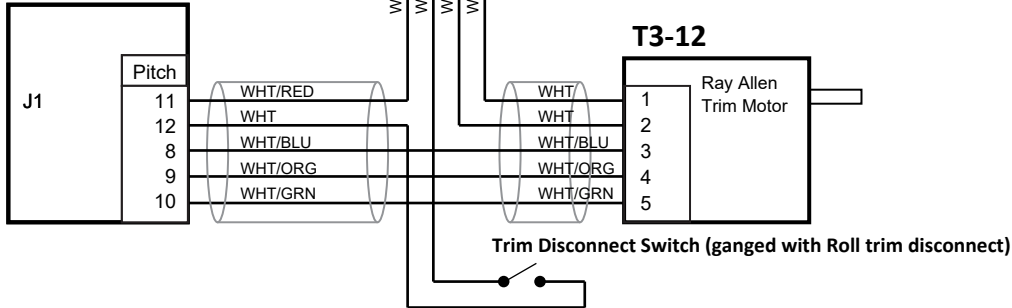

### GSA 28 (Yaw Servo)

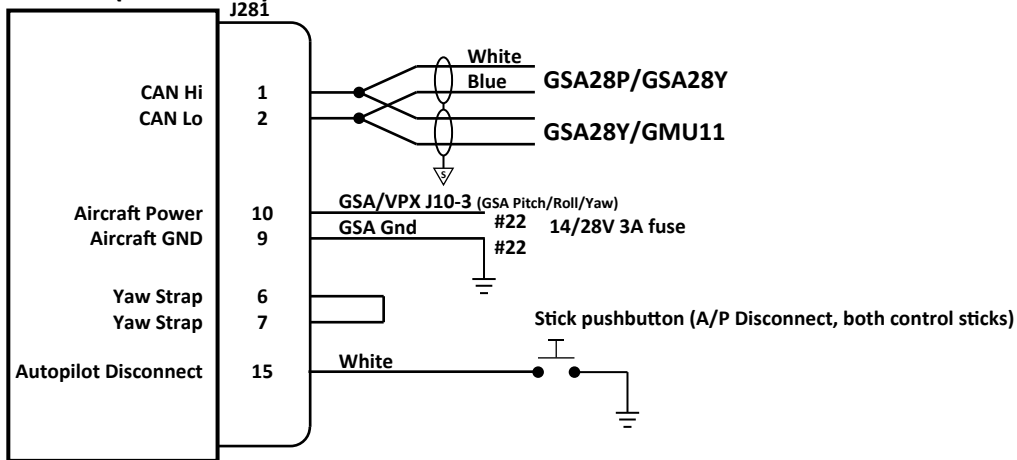

# GSU 25 (ADHRS)

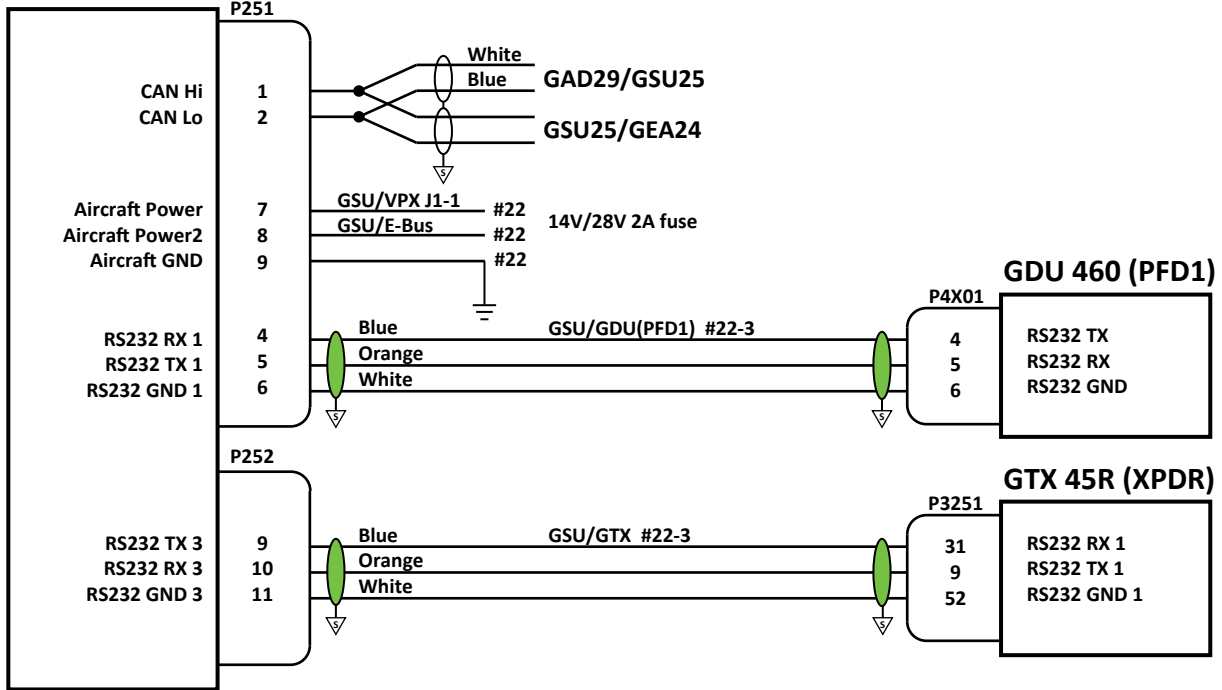

# GEA 24 (Engine Analyzer)

PAGE 31-2

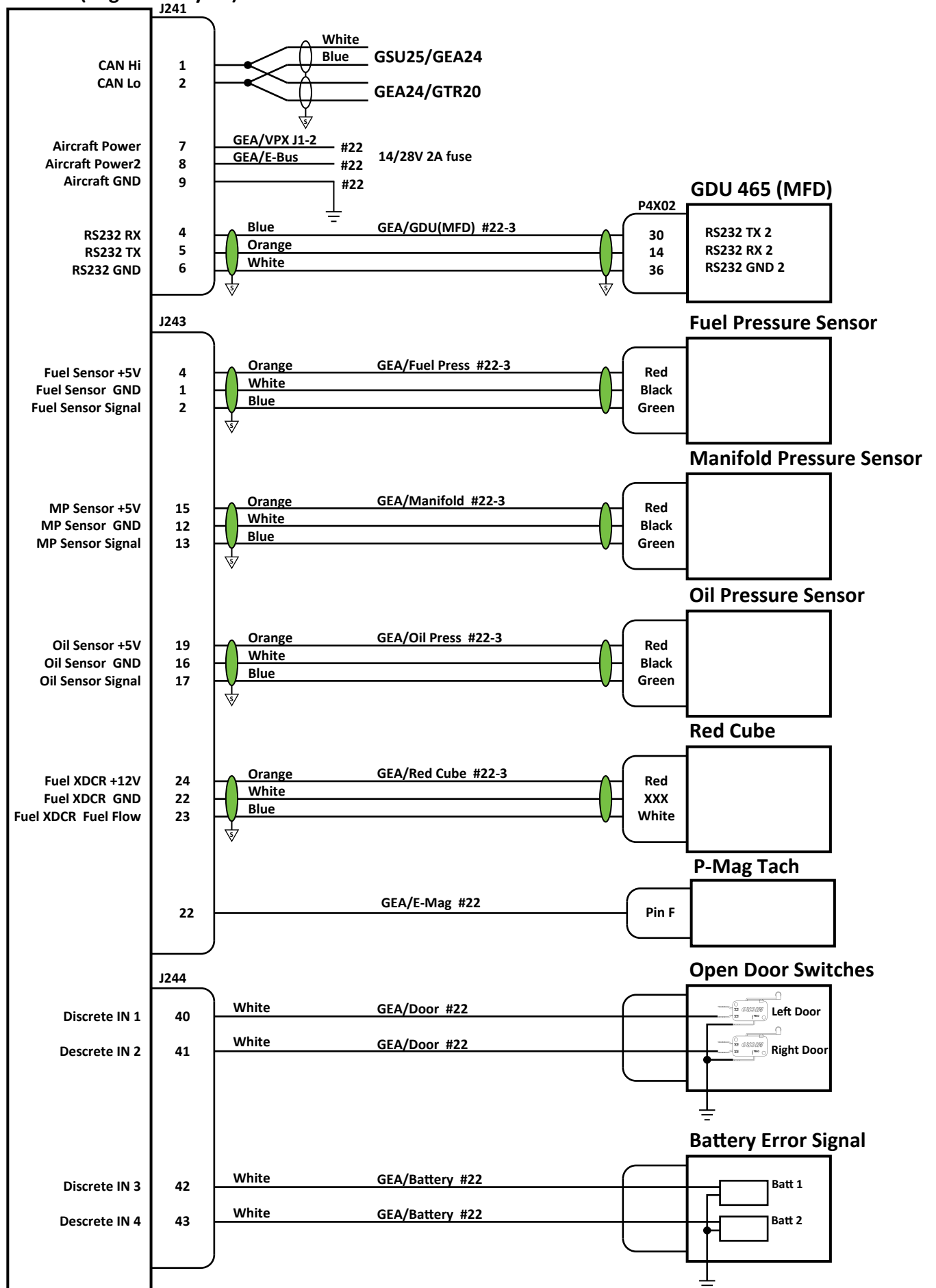

# GEA 24 (Engine Analyzer)

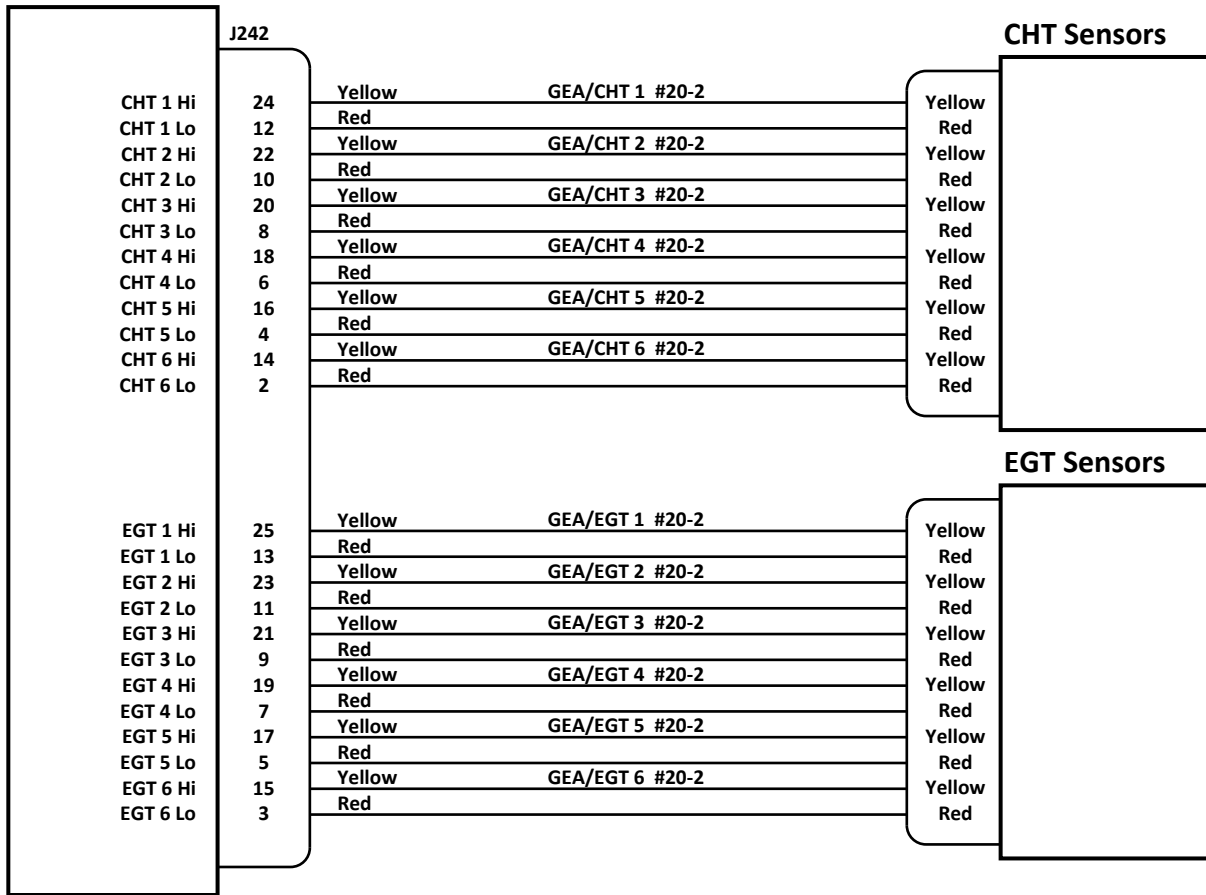

# GAD 13 (Temp Probe)

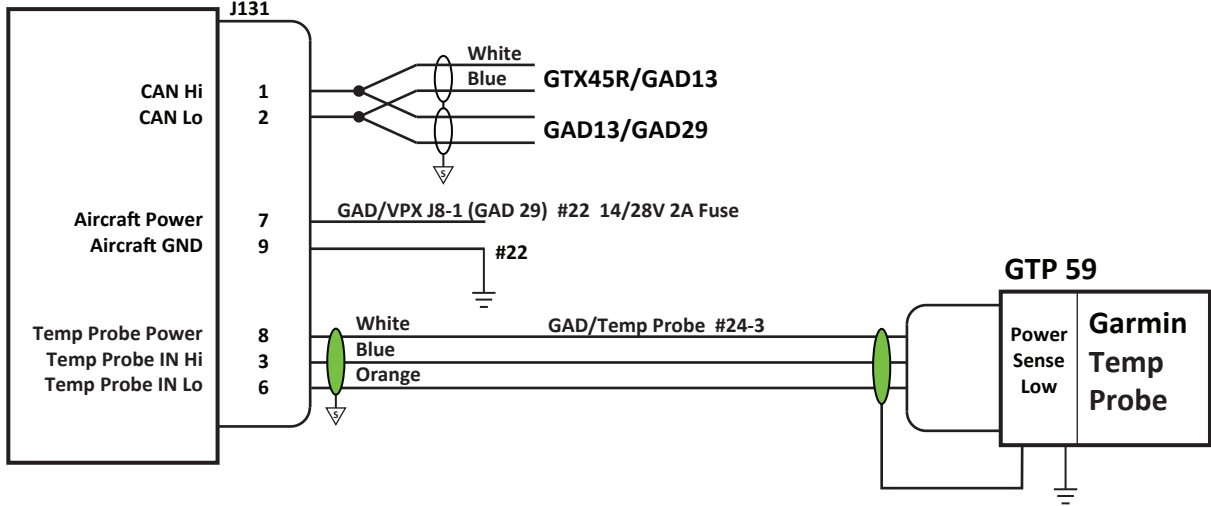



### ELT Panel

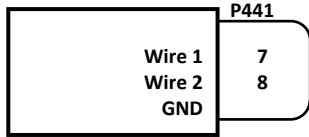

### ELT 345

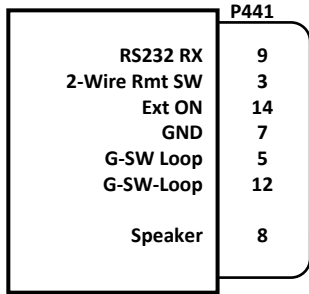

### GTN 650xi (GPS)

